

HAND HOLE SECTION

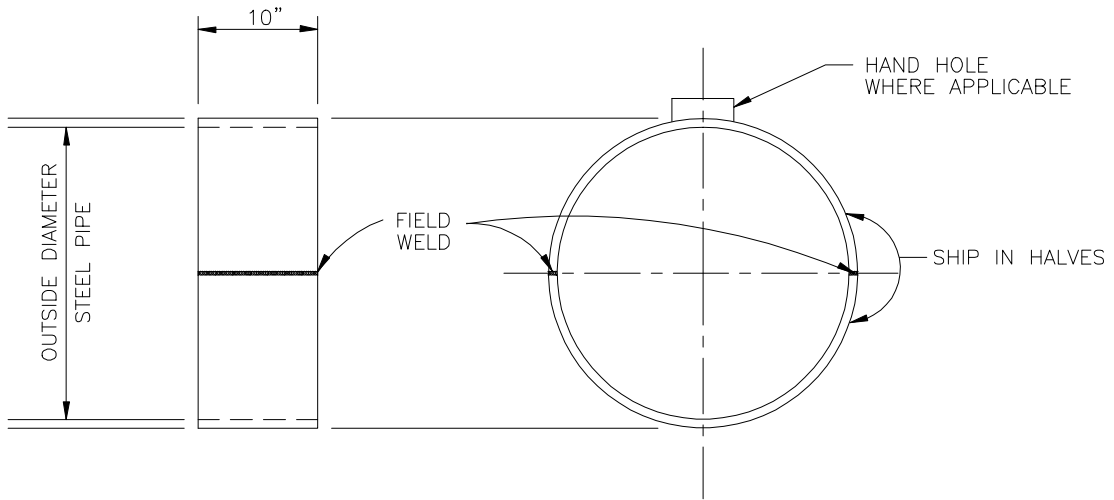

NOTES:

A MORTAR PER SECTION 4.5.7

PICO WATER DISTRICT

HAND HOLE SECTION

APP. mjgrajeda
MARK J. GRAJEDA
 GENERAL MANAGER

STANDARD
 DRAWING NUMBER

W-23

DATE: SEPT 2008