

**NO. 66-S COVER
W/READING LID**

WT.-88 #

OR

**NO. 66-TR STEEL
TRAFFIC COVER
W/READING LID**

WT.-70 #

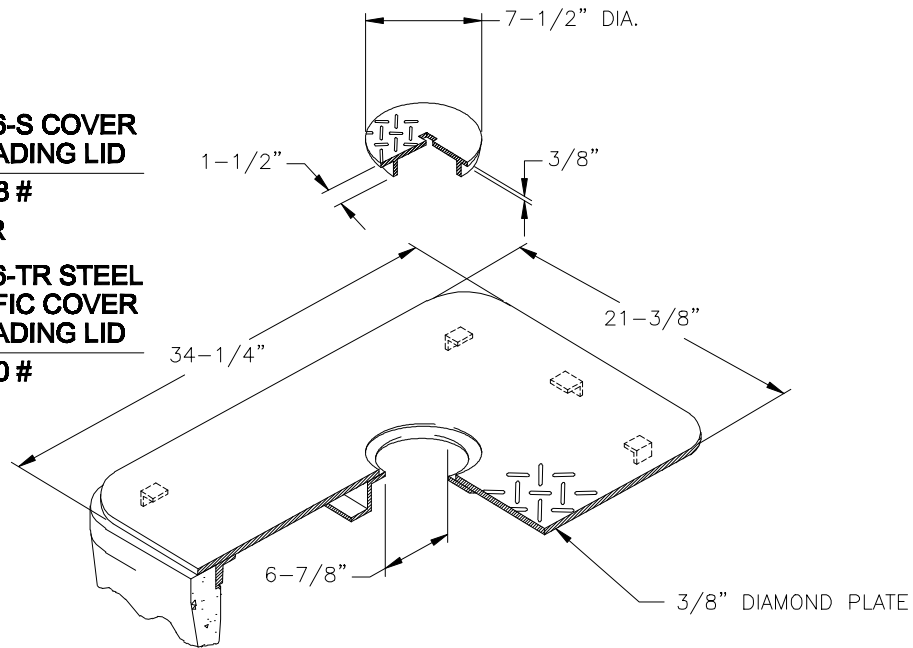

**NO. 66 BODY
WT.-160#**

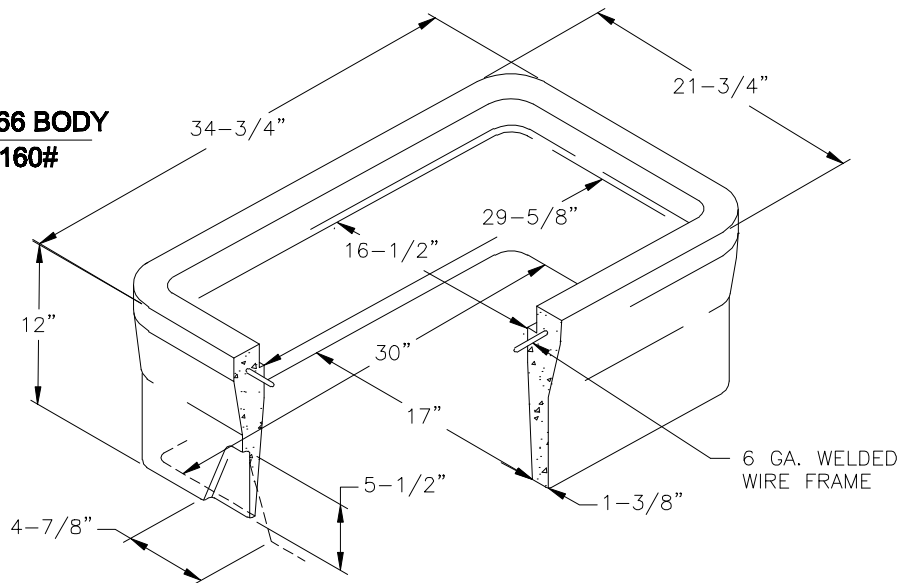

**NO. 65.S BODY
W/ COVER LID**

PICO WATER DISTRICT

**2" METER BOX, BROOKS;
ARMORCAST OR EQUAL**

APP. *mjgrajeda*
**MARK J. GRAJEDA
GENERAL MANAGER**

**STANDARD
DRAWING NUMBER**

W-27

DATE: SEPT 2008